

Parallel Programming

Libraries and implementations

EPSRC

NERC SCIENCE OF THE ENVIRONMENT



Outline

- MPI – distributed memory de-facto standard
 - Using MPI
- OpenMP – shared memory de-facto standard
 - Using OpenMP
- CUDA – GPGPU de-facto standard
 - Using CUDA
- Others
 - Hybrid programming
 - Xeon Phi Programming
 - SHMEM
 - PGAS



MPI Library

Distributed, message-passing programming



Message-passing concepts

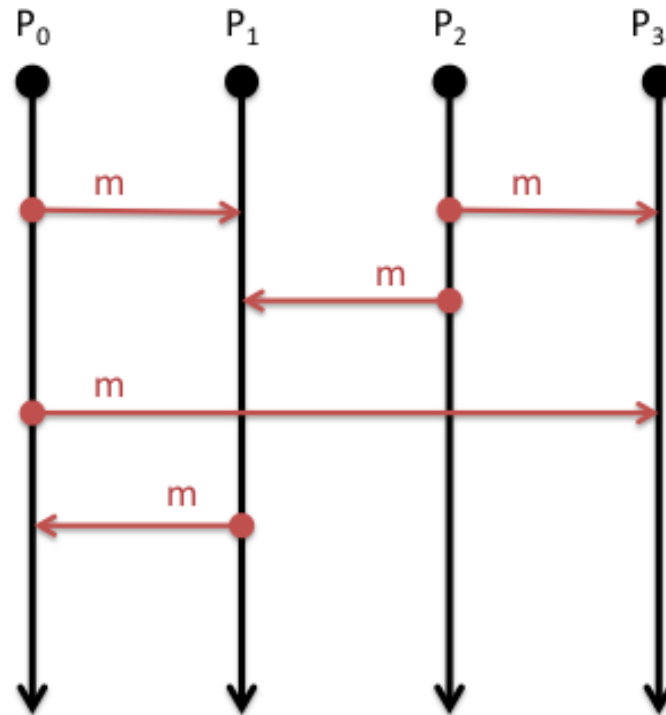

Explicit Parallelism

- In message-passing all the parallelism is explicit
 - The program includes specific instructions for each communication
 - What to send or receive
 - When to send or receive
 - Synchronisation
- It is up to the developer to design the parallel decomposition and implement it
 - How will you divide up the problem?
 - When will you need to communicate between processes?



Message Passing Interface (MPI)

- MPI is a portable library used for writing parallel programs using the message passing model
 - You can expect MPI to be available on any HPC platform you use
- Based on a number of *processes* running independently in parallel
 - HPC resource provides a command to launch multiple processes simultaneously (e.g. mpiexec, aprun)
- There are a number of different implementations but all should support the MPI 2 standard
 - As with different compilers, there will be variations between implementations but all the features specified in the standard should work.
 - Examples: MPICH2, OpenMPI



Point-to-point communications

- A message sent by one process and received by another
- Both processes are actively involved in the communication – not necessarily at the same time
- Wide variety of semantics provided:
 - Blocking vs. non-blocking
 - Ready vs. synchronous vs. buffered
 - Tags, communicators, wild-cards
 - Built-in and custom data-types
- Can be used to implement any communication pattern
 - Collective operations, if applicable, can be more efficient



Collective communications

- A communication that involves all processes
 - “all” within a communicator, i.e. a defined sub-set of all processes
- Each collective operation implements a particular communication pattern
 - Easier to program than lots of point-to-point messages
 - Should be more efficient than lots of point-to-point messages
- Commonly used examples:
 - Broadcast
 - Gather
 - Reduce
 - AllToAll



Example: MPI HelloWorld

```
int main(int argc, char* argv[])
{
    int size,rank;

    MPI_Init(&argc, &argv);
    MPI_Comm_size(MPI_COMM_WORLD, &size);
    MPI_Comm_rank(MPI_COMM_WORLD, &rank);

    printf("Hello world - I'm rank %d of %d\n", rank, size);

    MPI_Finalize();
    return 0;
}
```



OpenMP

Shared-memory parallelism using directives



Shared-memory concepts

- Threads “communicate” by having access to the same memory space
 - Any thread can alter any bit of data
 - No explicit communications between the parallel tasks

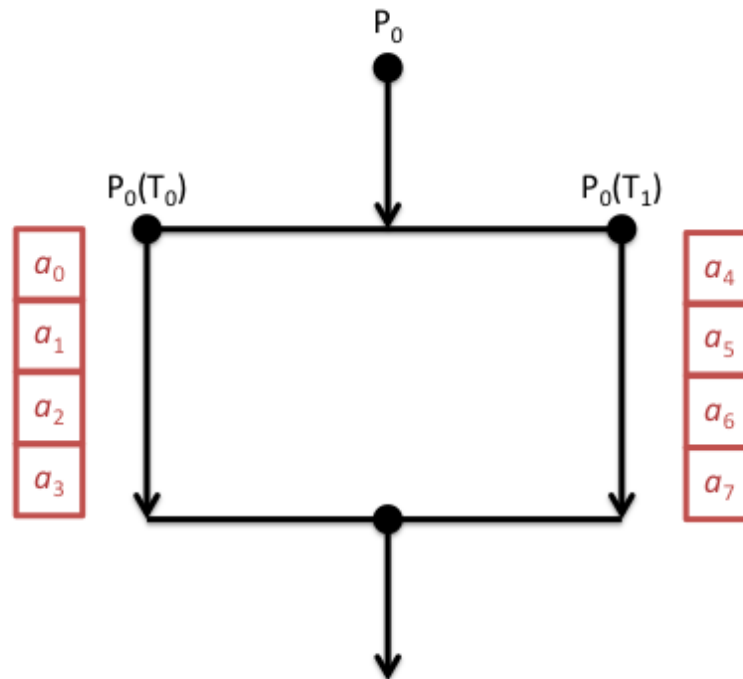

OpenMP

- OpenMP is an Application Program Interface (API) for shared memory programming
 - You can expect OpenMP to be supported by all compilers on all HPC platforms
- Not a library interface like MPI
 - You interact through directives in your program source rather than calling functions/subroutines
- Parallelism is less explicit than MPI
 - You specify which parts of the program you want to parallelise and the compiler produces a parallel executable



Loop-based parallelism

- The most common form of OpenMP parallelism is to parallelise the work in a loop
 - The OpenMP directives tell the compiler to divide the iterations of the loop between the threads

```
#pragma omp parallel shared(a,b,c,chunk) private(i)
{
    #pragma omp for schedule(dynamic,chunk) nowait
    for (i=0; i < N; i++) {
        c[i] = a[i] + b[i];
    }
}
```



Addition example

```
asum = 0.0
#pragma omp parallel \
shared(a,N) private(i) \
reduction(+:asum)
{
    #pragma omp for
    for (i=0; i < N; i++)
    {
        asum += a[i];
    }
}
printf("asum = %f\n", asum);
```

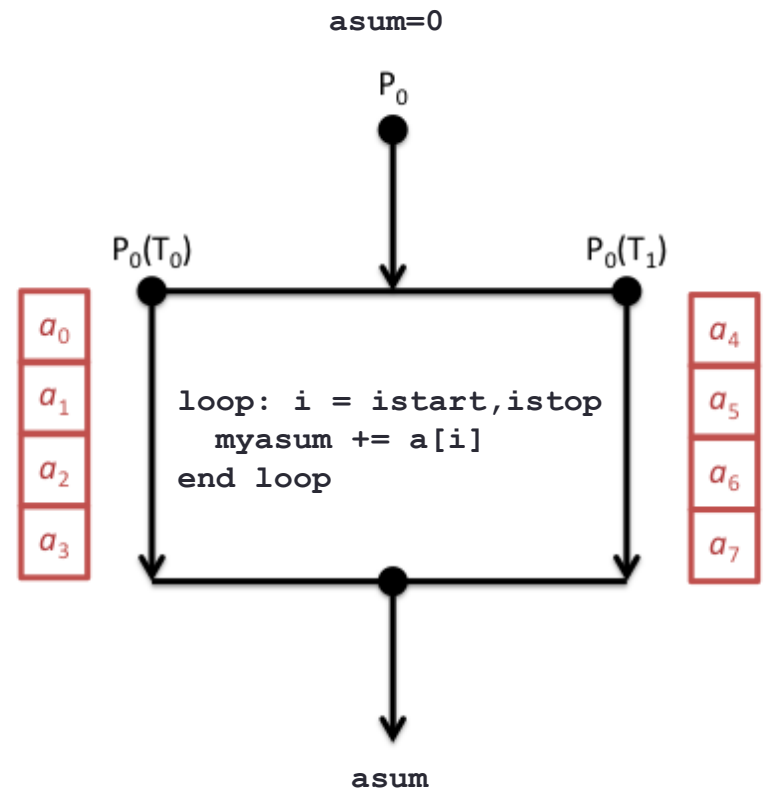

CUDA

Programming GPGPU Accelerators



CUDA

- CUDA is an Application Program Interface (API) for programming NVIDIA GPU accelerators
 - Proprietary software provided by NVIDIA. Should be available on all systems with NVIDIA GPU accelerators
 - Write GPU specific functions called *kernels*
 - Launch kernels using syntax within standard C programs
 - Includes functions to shift data between CPU and GPU memory
- Similar to OpenMP programming in many ways in that the parallelism is implicit in the kernel design and launch
- More recent versions of CUDA include ways to communicate directly between multiple GPU accelerators (*GPUDirect*)



Example:

```
// CUDA kernel. Each thread takes care of one element of c
__global__ void vecAdd(double *a, double *b, double *c, int n)
{
    // Get our global thread ID
    int id = blockIdx.x*blockDim.x+threadIdx.x;

    // Make sure we do not go out of bounds
    if (id < n)
        c[id] = a[id] + b[id];
}

// Called with
vecAdd<<<gridSize, blockSize>>(d_a, d_b, d_c, n);
```



OpenCL

- An open, cross-platform standard for programming accelerators
 - includes GPUs, e.g. from both NVIDIA and AMD
 - also Xeon Phi, Digital Signal Processors, ...
- Comprises a language + library
- Harder to write than CUDA if you have NVIDIA GPUs
 - but portable across multiple platforms
 - although maintaining performance is difficult



Others

Niche and future implementations



Other parallel implementations

- Partitioned Global Address Space (PGAS)
 - Coarray Fortran, Unified Parallel C, Chapel
- Cray SHMEM, OpenSHMEM
 - Single-sided communication library
- OpenACC
 - Directive-based approach for programming accelerators



Summary



Parallel Implementations

- Distributed memory programmed using MPI
- Shared memory programmed using OpenMP
- GPU accelerators most often programmed using CUDA

- Hybrid programming approaches (e.g. MPI/OpenMP) are becoming more common
 - They match the hardware layout more closely

- A number of other, more experimental approaches are available

